



ASTRONERGY



ASTRO N5s

CHSM54N(BL)-HC
CHSM54N(BLH)-HC
Monofacial Series

420~440W

Warranty

15 15-year Product Warranty

30 30-year Linear Power Warranty

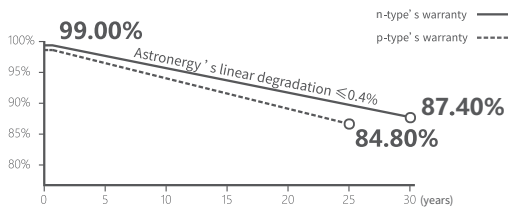

Key Features

- Suitable for distributed projects
- High power
- High reliability
- Easy to install and transport



ISO 9001:2015:ISO Quality Management System
ISO 14001:2015:ISO Environment Management System
ISO 45001:Occupational Health and Safety
The first solar company which passed the Nord IEC/TS 62941 certification audit



Tier 1
BloombergNEF



420~440W

POWER RANGE

0~+3%

POWER SORTING

22.5%MAX MODULE
EFFICIENCY**≤ 1.0%**FIRST YEAR
POWER DEGRADATION**≤ 0.4%**YEAR 2-30
POWER DEGRADATION

Mechanical Specifications

Outer dimensions (L x W x H)	1722 x 1134 x 30 mm
Cell type	n-type mono-crystalline
No. of cells	108 (6*18)
Frame technology	Aluminum, black anodized
Front glass thickness	3.2 mm(Anti-reflective coating, tempered glass)
Cable length (Including connector)	1200 mm
Cable diameter (IEC/UL)	4 mm ² / 12 AWG
① Maximum mechanical test load	5400 Pa (front) / 2400 Pa (back)
Connector type (IEC/UL)	HCB40 (Standard) / MC4, MC4-EVO2A (Optional)
Module weight	21.3 kg
Packing unit	36 pcs / box
Weight of packing unit (for 40'HQ container)	811 kg
Modules per 40' HQ container	936 pcs (Subject to sales contract)

① Refer to Astronergy crystalline installation manual or contact technical department.
Maximum Mechanical Test Load=1.5×Maximum Mechanical Design Load.

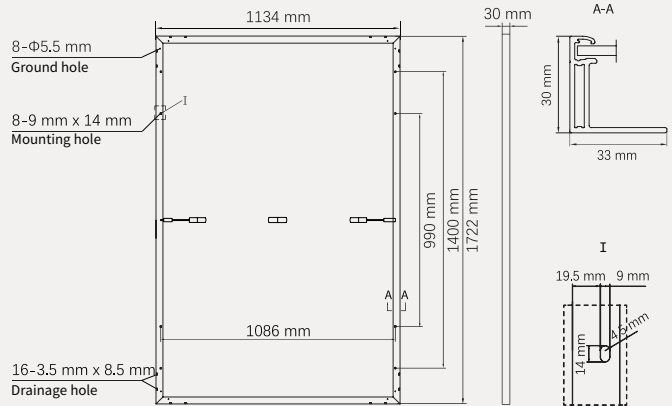

Electrical Specifications

STC: Irradiance 1000W/m², Cell Temperature 25° C, AM=1.5

Rated output (Pmpp / Wp)	420	425	430	435	440
Rated voltage (Vmpp / V)	31.93	32.10	32.27	32.44	32.61
Rated current (Impp / A)	13.15	13.24	13.33	13.41	13.49
Open circuit voltage (Voc / V)	38.00	38.20	38.40	38.60	38.80
Short circuit current (Isc / A)	13.87	13.98	14.09	14.19	14.30
Module efficiency	21.5%	21.8%	22.0%	22.3%	22.5%

NMOT: Irradiance 800W/m², Ambient Temperature 20° C, AM=1.5, Wind Speed 1m/s

Rated output (Pmpp / Wp)	315.8	319.6	323.4	327.1	330.9
Rated voltage (Vmpp / V)	30.06	30.21	30.37	30.53	30.70
Rated current (Impp / A)	10.51	10.58	10.65	10.71	10.78
Open circuit voltage (Voc / V)	36.10	36.29	36.48	36.67	36.85
Short circuit current (Isc / A)	11.20	11.28	11.37	11.46	11.54

Temperature Ratings (STC)

Temperature coefficient (Pmpp)	-0.29%/°C	No. of diodes	3
Temperature coefficient (Isc)	+0.043%/°C	Junction box IP rating	IP 68
Temperature coefficient (Voc)	-0.25%/°C	Max. series fuse rating	25 A
Nominal module operating temperature (NMOT)	41±2°C	Max. system voltage (IEC/UL)	1000V _{dc} or 1500V _{dc}

Operating Parameters

Curve

Current-Voltage (430W)

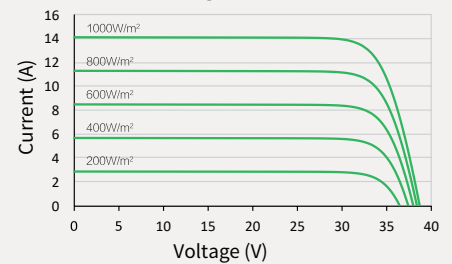

Power-Voltage (430W)

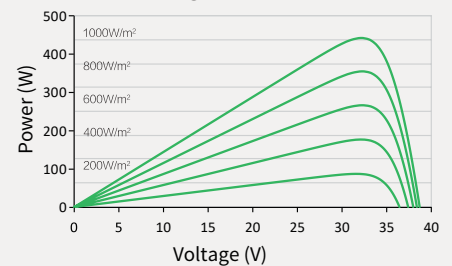

Current-Voltage (430W)

